



ARABIAN HORSE ASSOCIATION

Judges & Stewards

TRAIL HORSE WESTERN/ENGLISH/IN-HAND/WALK-JOG

Table of Contents

AR209	1
Objectives of Trail Class.....	1
Gait Definitions.....	2
Judging of Gaits	2
Class Specifications.....	3
Attire/Tack and Equipment	3
Course Designer.....	3
Courses	3
Obstacles	4
Trail Obstacle Mandatory Dimensions	5
Trail Definitions	8
Class Specifications.....	8
Score Sheet/Scribe	8
Scoring	9
Sample Score Sheet:.....	10
Penalty Illustrations.....	11

AR209

The Arabian Working Western Horse should exhibit breed type while performing its task-oriented disciplines. Breed type includes a natural tail carriage. No horse may compete in a class in the Arabian Division with a tail that has been altered in any manner or by any means. See AR105.2b.

a. Judges must penalize horses exhibiting unnatural Arabian appearance (unnatural tail carriage). Conversely, horses with natural Arabian appearance (tail carriage) showing expression that is not angry or offensive must not be penalized.

b. A horse’s tail carriage must be considered altered when it is obviously and consistently carried in an unnatural manner.

c. In all scored Working Western classes, a horse exhibiting unnatural Arabian appearance must be assessed a 10- point penalty.

d. In non-scored Working Western classes, a horse exhibiting unnatural Arabian appearance must be penalized and positioned last in the class. BOD 6/20/23 Effective 12/1/23

Objectives of Trail Class

- *A Trail horse is one that can maneuver through a course of obstacles with physical skill, expression, and a good mental attitude.*
- *It should travel through and between obstacles with an inquisitive desire to go forward without compromising its calm, relaxed attitude, and way of going.*
- *It should approach each obstacle squarely with authority and correct form, with its own style, yet maintaining its willingness to be dictated to completely by the exhibitor with no apparent resistance.*
- *Maximum credit should be given to the trail horse that negotiates its way through an entire course efficiently, in a timely manner, without excessive hesitation, and shows curiosity, expression, smoothness and style.*
- *The horse should negotiate the course in a manner that raises the degree of difficulty without sacrificing carefulness, control, and attitude. Ultimately, the trail horse is skillful, eye appealing, confident, and leaves one with the impression of being sure, safe and a pleasure to ride over a course of obstacles.*
 - **Classes – Under Saddle and In-hand**
 - Trail classes under saddle may be offered for Western or English, but

the two styles are not to be combined into one class at any time as there are distinct differences.

- Trail classes in-hand may be offered for Western and English styles and the styles may be combined.
- All entered exhibitors will be allowed to walk and inspect the course with the judge and with the course designer, if present, prior to the start of the class. In amateur and junior exhibitor classes, exhibitors may be accompanied by their trainer.
- There is no rail work
- There are no time outs
- Order of go to be drawn
- Note: ASTM helmets are not required for Western trail classes with jump obstacles but are required in all under saddle English Trail classes.

Gait Definitions

Gaits Definitions for non-Ranch classes

a. The walk is a natural, flat-footed, four-beat gait. The horse must move straight and true at the walk. The walk must be alert, with a stride of reasonable length in keeping with the size of the horse.

b. The jog is a smooth, ground-covering two-beat diagonal gait. The horse works from one pair of diagonals to the other pair. The jog should be square, balanced and with straight, forward movement of the feet. Horses walking with their back feet and trotting in the front are not considered performing the required gait. When asked to extend the jog, it moves out with the same smooth way of going.

c. The lope is an easy, rhythmical three-beat gait. Horses moving to the left should lope on the left lead. Horses moving to the right should lope on the right lead. Horses traveling at a four-beat gait are not considered to be performing at a proper lope. The horse should lope with a natural stride and appear relaxed and smooth. It should be ridden at a speed that is a natural way of going. The head should be

carried at an angle which is natural and suitable to the horse's conformation at all gaits.

Judging of Gaits

1. There will be an order of priority for evaluating gaits. This hierarchy of consideration must be adhered to by judges and will be a great aid to exhibitors for how their horses should be presented and are listed in order of importance.

a. Correctness-the most important element judges must assess if the exhibitor has performed each gait correctly during all, or the majority of the class, in order to have a correct or positive evaluation. For western and English gaits, this includes a four-beat walk, two-beat jog/trot and three-beat lope/canter. The distinctness of the designated cadence for the gait being performed is essential.

b. Quality is the second most important element and can only be considered positively if the gait performance has complied with the first element of correctness. When evaluating the pleasing characteristics of a gait, among many considerations, judges must consider overall gracefulness, relaxed expression, topline, softness of movement, consistency, and length of stride of the designated gait.

c. Degree of Difficulty-is the least important and must only be considered if the requirement for correctness has been met and combination of correctness and quality allow the performance to be considered for placement. Difficulty is greatly influenced by exhibiting a pleasure horse at a pace and speed that allows for correctness and best quality of a gait for that individual. A performance of a walk that is ground covering and free flowing has a high degree of difficulty. A jog/trot or lope/canter that is performed with a slow rhythm without sacrificing correctness or quality has a high degree of difficulty. Slowness that sacrifices correctness or negatively impacts quality must be considered incorrect and a poor performance at best.

Class Specifications

- **Under Saddle**
 - OPEN, AMATEUR, LADIES, GENTLEMEN
 - JUNIOR HORSE
 - GREEN: A Green Trail Horse is a horse of any age in its first or second competition year showing in any trail class at AHA/USEF/EC competition.
- **In-Hand**
 - OPEN, AMATEUR, JUNIOR EXHIBITOR
 - Weanlings, Yearlings, Two-year olds, Two & under, Three & over
 - Colts, Stallions, Fillies, Mares and Geldings

Attire/Tack and Equipment

- Western Trail Under Saddle
 - **Reference AR211. Junior Working Western Horses may compete in any permitted bridle when showing in Working Western classes not restricted to junior horses. If shown in Junior horse restricted Working Western class(es), they must compete in a hackamore bridle or snaffle bit, as required in the class specifications.**
 - USEF Western Equipment Booklet <https://www.usef.org/forms-pubs/5RH4DNG2aJ4/western-equipment>
- English Trail Under Saddle
 - Reference AR211.2
 - Horses entered in English Junior Horse Trail classes must be shown in a snaffle bit as appropriate to style of attire. Hackamores are not permitted in English Trail.
- In-hand Trail
 - Tack: Refer to AR211.3
 - Western attire: Reference AR211.4a & b
 - English attire: Reference AR211.4c.
 - In-hand attire: Reference AR211.4d

Course Designer

- National Championship competitions are required to contract with a course designer (CD), separate from one of the judges.

- For all other competitions, including Regional competitions, contracting a CD is recommended. A judge or other official can serve as CD at any competition except National Championships.
- The name of the CD should appear in the prize list. The CD should be present and available to the trail arena at all times during the trail class.
- The CD must be a USEF/EC Senior Member in good standing.
- Conflict of interest: neither the CD nor a member of the CD's family may be a trainer, coach, exhibitor, or rider in classes which the CD designs.

Courses

- Western and English Under Saddle Trail classes: The course must be designed to require each horse to show all three (3) gaits, (walk, jog/trot at least thirty (30) feet, lope/canter right and left lead) somewhere between and/or over obstacles as part of its work, and quality of movement and cadence should be considered as part of the obstacle score. Unnecessary delays while approaching or negotiating an obstacle shall be penalized.
- In-hand Trail classes: To include a walk and jog/trot of suitable duration to determine the way of going. Management is encouraged to design courses that can be negotiated in ninety (90) seconds.
- A trail course should be designed with safety as the first priority.
- All obstacles/elements of obstacles must be safe and in good condition
- Courses may be altered by the judge prior to the course walk.
- Minimum of 6 obstacles/maximum of 10, with the exception of National Championships
- Courses must be posted at least 12 hours before scheduling start time of class.

- Regionals – 24 hours
- Nationals – 24 hours
- Consideration should be given to ages and experience level of the class(es) being offered. In addition, there are specific rules for Walk/Trot 10 and Under Trail classes.
- Obstacles can be divided into three types, and each type should be represented in each course.
 - Control obstacles– allow horse to demonstrate athletic skills and concentration ability. Examples: gates, back throughs, side passes, turns on the forehand or rear, serpentine
 - Calmness obstacles – allows the personality and temperament of the horse to be shown. Examples: water, plastic, brush, plants, carrying objects, dally and drag
 - Agility obstacles – demonstrate the horse’s awareness of its surroundings by the way it moves and by foot placement. Examples: jumps, walk-overs, trot/jog overs, canter/lope overs, bridge.
 - The course should designate where the horse is to show all three gaits: walk, jog/trot, lope/canter. Walk-Trot 10 & Under classes show only at the walk and either the jog or trot.



Obstacles – reasoning behind selection and measurements – See current USEF Arabian Division rules and following chart for specific dimensions and placement of obstacles. The judge has the right to alter the course.

- **Measurements**
 - Minimum/maximum distances are measured between facing edges of the pole or pylon at the optimum point of crossing by the track indicated in the trail course pattern.

Figure horse’s wheelbase at five feet front hooves to back hooves.



- There should be sufficient space between designated obstacles for the jog/trot and lope/canter requirements. Consider at least 30 feet for a jog/trot and 50 feet for the lope/canter.
- **Elevated poles** must be in a pole holder e.g. trail blocks, trail risers, standard jump cups or similar type supports. Shown here are examples of two types of acceptable holders for elevated poles.
 - Rolling poles are not permitted.
- **Walk-overs** can be set as single poles or in a series of multiple poles. These should simulate what may be encountered by a horse and rider on a trail. For in-hand trail, walk-overs should simulate what could be reasonably expected of a horse being led.
 - Rolling poles are not permitted.
- **Lope-overs (Western) and Canter Overs (English)** can be set as single poles or in a series of multiple poles. These should simulate what may be encountered by a horse and rider on a trail. Lope-overs and canter-overs are not allowed in In-hand classes.
- **Jumps** can be single or in combinations.



Box jump

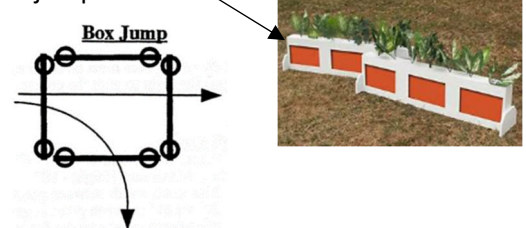

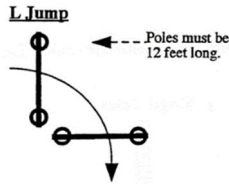

- **Cavaletti** can be jog-overs (Western) Cavaletti/trot-overs (English) or jog/trot-overs for in-hand trail. Jog-over/trot-overs provide an opportunity for the exhibitor to choose the best path based on their horses length of stride and method of being shown (English or Western)
- **Back throughs** can be on the ground or elevated and in any configuration that is reasonable to expect on the trail or by a horse being led.
- **Side passes** can be over a single pole or can be a slot. Two poles would be used for a slot side pass with the course

indicating if the front feet or the hind feet are in the slot during the maneuver.

- **Serpentines (trot/jog arounds)** can be around pylons or something of sufficient height (18" minimum) to be easily seen by the horse and rider. Guardrails can be placed to either side of the pylons to increase the difficulty of the obstacle.
- **Gates** should have the latch/rope at approximately 60" for ridden trail classes; for in-hand trail, the latch/rope must be operable by all handlers.
- **Bridges** must be sturdy, safe, and have a non-slip surface. Side rails are not required. Poles are not to be placed on a bridge.

Trail Obstacle Mandatory Dimensions

<i>Obstacle</i>	<i>Western</i>	<i>English</i>	<i>In-hand</i>	<i>Walk-trot</i>
Walk overs				
Single Poles	Max height 16"	Max height 16"	Max height 12"	If elevated, maximum height 8"
Multiples	Max height 10"	Max height 10"	Max height 8"	Only 2 can be elevated poles with maximum height 8"
Minimum width between poles	20"-24" or multiples thereof	20"-24" or multiples thereof	20"-24" or multiples thereof	20"-24" or multiples thereof
Lope overs	Distance 6' - 6'6" preferred	N/A	N/A	N/A
Canter overs	N/A	6'6" – 8'; 7'6" preferred	N/A	N/A
Jumps	Note: maximum width between standards 4'			
Mounted	Max height 24"	Max height 24"	N/A	N/A
Amateur/Junior to Ride classes	Cross rails; max height at top of center of pole intersection max 18". Angle of poles not to	Cross rails; max height at top of center of pole intersection max 18". Angle of poles not to	N/A	N/A

Obstacle	Western	English	In-hand	Walk-trot
	exceed approx. 30 degrees	exceed approx. 30 degrees		
Lead over	N/A	N/A	Max height 12"	N/A
Combinations	12' for one stride; 6' for no stride	12' for one stride; 6' for no stride	12' for one stride; 6' for no stride	N/A
Box Jumps and L jumps	Poles must be at least 12' long	Poles must be at least 12' long	Poles must be at least 12' long	N/A
Cavaletti	Note: space is measured between poles			
	Jog overs: 3' – 3'6" apart or multiples thereof	Trot overs: 3'6" – 4' apart. 4' preferred	Singles or multiples – maximum height 6"	Same spacing as WS & ENG Trail
	Lope overs: 6' – 7' apart of multiples thereof	Canter overs: 6'6" – 8' apart. 7'6" preferred		N/A
Back Throughs				
On ground	Min. 36" between	Min. 36" between	Min. 36" between	Must be straight; width 42" or greater
Elevated	Min. 40" between	Min. 40" between	Min. 40" between	Must be straight; width 42" or greater
Barrels	Min. 42" between	Min. 42" between	Min. 42" between	Must be straight; width 42" or greater
Side Passes	Note: if tall standards are used, dimensions can be looser			
Single pole	Up to 24" high	Up to 24" high	Up to 6" high	N/A
Slots	Never closer than 36" wide, space measured between poles	Never closer than 36" wide, space measured between poles		N/A
Serpentine				
	Jog around: Cones min. 8' apart (base to base). Guardrails, if used, should be 6' to either side of cones.	Jog around: Cones min. 8' apart (base to base). Guardrails, if used, should be 6' to either side of cones.	Jog around: Cones min. 8' apart (base to base). Guardrails, if used, should be 6' to either side of cones.	Jog around: No more than 5 consecutive pylons. Min. 10' apart WS W/T with guardrails, if used, 10-12' feet to either side of cones. Min. 12' apart English W/T with guardrails, if used, 10-12' to either side of cones.
	N/A	N/A	N/A	Walk around

Obstacle	Western	English	In-hand	Walk-trot
				No more than 5 consecutive pylons. Min. 8' apart. English W/T min. 6' apart. Guardrails, if used, should be 4-5' to either side of pylons for Western W/T; 5-6'' for English W/T
Turns				90 or 180 degrees with a box or confined area no smaller than 8'x8' 270 or 360 degree turns, confined area no less than 10'x10'
Gate May be fixed/hinged gate or rope gate.	Approx. 60'' high, latch available at that height.	Approx. 60'' high, latch available at that height.	Gate must be operable by all handlers.	Pass through an open gate. A single non-elevated walk over pole may be placed in the "open" gate.
Bridge	Must be sturdy design with non-slip surface.			
	Min. 3' wide, 6' long. No higher than 12''	Min. 3' wide, 6' long. No higher than 12''	Min. 3' wide, 6' long. No higher than 12''	Min. 36'' wide, 6' long. No higher than 8''
Any other maneuvers	Figure horse's wheelbase at 5', front hooves to back hooves.			

- **Prohibited obstacles for Western, English, In-hand include but are not limited to:**
 - Live animals
 - Animal hides
 - PVC poles
 - Dismounting
 - Rocking or moving bridges
 - Water box with floating or moving parts
 - Flames, dry ice, fire extinguisher, etc.
 - Logs or poles elevated in a manner that permits such to roll

- Tarps are prohibited to be used within an obstacle, defined as where the entry will be expected to walk, jog, **canter**/lope or back. They can be used for decorative purposes but must be secured.
- Hay bales
- Rolling Poles
- **Prohibited for Walk/Trot**
 - Water
 - Water boxes (empty)

- Drags
- Pick-up object
- Open/close gates
- Elevated poles
- Rolling poles
- Side pass

Trail Definitions

1. Knockdown: When any component, element, or portion of an obstacle is displaced from its original position-by horse or exhibitor.
2. Refusal: Any action taken by the horse to avoid performing an obstacle, part of a combination of obstacles or portion of a trail course. These actions may include, but are not limited to the following:
 - a. Balking: Any action that results in a horse blatantly and continuously refusing an exhibitor's command.
 - b. Evading or running past an obstacle to be negotiated.
 - c. Each complete loss of the gate determined by the entry letting go of gate or dropping a rope gate.
 - d. Any blatant action by the horse that demonstrates an unwillingness to approach, negotiate and/or complete an obstacle.
 - e. At the judge's discretion or when a judge has deemed three (3) refusals have occurred at an obstacle the exhibitor will proceed to the next obstacle. (In multiple judging situations the call judge will determine when to instruct the exhibitor to proceed to the next obstacle.) Any time a judge instructs an exhibitor to proceed to the next obstacle, a five (5) point penalty will apply for being asked to move to another obstacle and as such is not in accordance with course direction. This penalty is in addition to the two (2) five (5) point penalties received for refusals or blatant disobedience for a total of three (3) five (5) point penalties.
4. Off Course:
 - a. Taking an obstacle in the wrong direction.
 - b. Deliberately failing to enter, exit, or work obstacle from correct side or direction.
 - c. Negotiating an obstacle in the wrong sequence including skipping an obstacle unless directed by the judge.

- d. Not following the correct line of travel (i.e. the drawn pattern and Judge's instruction/direction).
- e. Pulling gate when designated to push in course directions (or vice versa) or when using a rope gate, walking through gate when designated to back through (or vice versa).
- f. Sidepassing the wrong end of a horse in slot.
- g. Riding or leading outside designated boundary marker of the course.

Class Specifications

- In-hand Trail: Judges should consider the overall appearance of the horse, conditioning, grooming and the equipment in the overall score.
 - Also to be considered is the correctness of the horse while being led.
 - For safety reasons, those handlers continuously holding the chain on the lead, tightly coiling the lead shank around the hand, or dragging the lead shank must be penalized.

Score Sheet/Scribe

- Judges are required to use the most current AHA Trail Class score sheets.
 - The score sheets are available on the AHA website: https://www.arabianhorses.org/export/content.export/judges-stewards/js-docs/Trail_Score.pdf
 - Hint: when evaluating the trail course and adding obstacle names/numbers to the score sheet, mark on the trail pattern where one obstacle (often composed of multiple elements) ends and the next begins. Share this information with the scribe to make it easier for any penalties to be assigned to the correct obstacle/maneuver.
- When conveying penalties to the scribe, say "penalty" then the penalty. This method eliminates confusion on whether you are giving a maneuver score or a penalty.

- Check from time to time to make sure the scribe is keeping up with you and recording scores/penalties correctly.
- The scribe is to use a #2 pencil or comparable lead thickness to ensure readability; best to have a good eraser.
 - Encourage the scribe to keep a running subtotal of scores without deducting penalties in the subtotal.
 - Penalties are deducted from the total of the obstacle scores at the end of the work
- If necessary, the calculator function on a mobile phone can be used to double check a score, especially when there are a number of penalties.

Scoring

- All horses enter the arena with a score of 70. With each obstacle, the judge will instruct a scribe to assign a score as well as any appropriate penalties if one or more occurs.
 - At the end of the work, obstacle scores will be totaled.
 - Any penalties will then be subtracted to arrive at a final score.
- All horses are judged from the time they enter the arena until the completion of the last obstacle.
 - Hint: Determine in advance the optimum position in the ring to allow you to evaluate each obstacle as fully as possible. This may be inside or outside of the arena.
- Judge(s) may review official video (if available) on no score, zero, or 5 point penalties only. Refer to AR214.5 (Video review is solely the judge(s) decision.)
- Credit earning – working obstacles with appropriate speed, style and caution, responsive to rider's cues, ability to work their way through a course.
- Non-credit earning – unnecessary delay in approaching and/or negotiating an obstacle as well as artificial appearance while negotiating obstacles.
- Half point increments can be used from +3 to -3.

- Each obstacle will be scored as follows:
 - **+3 EXCELLENT:** The horse approaches and negotiates obstacle in correct form with definite style. The horse performs in an efficient manner with curiosity and athleticism, while maintaining the qualities of an ideal trail horse. The horse's performance over the obstacle is VISUALLY IMPRESSIVE.
 - **+2 VERY GOOD:** The horse approaches and negotiates obstacle in correct form with noticeable style. This horse definitely displays many qualities of the ideal trail horse. The horse's performance over the obstacle is VISUALLY ATTRACTIVE.
 - **+1 GOOD:** The horse approaches and negotiates obstacle in correct form with some degree of style. This horse may display some qualities of the ideal trail horse, but lacks those qualities to the degree they are exhibited by the Very Good or Excellent performer. The horse's performance over the obstacle is VISUALLY PLEASING.
 - **0 AVERAGE:** For the most part, horse approaches and negotiates obstacle in correct form. Minimal style is exhibited. If the horse's performance displays any qualities of the ideal trail horse they are negated by slight errors in form. The horse's performance over the obstacle leaves a visually NEUTRAL IMPRESSION.
 - **-1 POOR:** The horse fails in some way to approach and/or negotiate obstacle in correct form. There is a noticeable void in some of the qualities of the ideal trail horse. Willingness to guide or control may have been compromised but not safety.
 - **-2 VERY POOR:** The horse approaches and negotiates obstacle, but noticeably fails to do so in correct form. There is a definite deficiency in the qualities of the ideal trail horse. Safety may have been compromised. The horse exhibits noticeable resistance.

- **-3 EXTREMELY POOR:** The horse approaches and/or negotiates obstacle in unacceptable form, but avoids elimination. This horse's performance is probably reckless, careless, and/or dangerous. The horse exhibits significant resistance towards the rider's commands.

See current rules for complete list of Penalties.

REMEMBER: Effective 12/1/2023

In all scored Working Western classes, a horse exhibiting unnatural Arabian appearance must be assessed a 10- point penalty.

Sample Entry on Score Sheet:

Example 1:	
1st Obstacle: Poor	5th Obstacle: Good
2nd Obstacle: Average	6th Obstacle: Good
3rd Obstacle: Average	7th Obstacle: Average
PENALTY: Stepping 2 Feet Outside Confining Element.	PENALTY: Knockdown
4th Obstacle: Good	8th Obstacle: Very Poor

EXAMPLE-1:



DRAW	ENTRY		1	2	3	4	5	6	7	8	9	10	11	12	Penalties	
1	101	Penalties			5				3						8	
		Score	-1	0	0	+1	+1	+1	0	-2						Score
		Subtotal	69			70	71	72		70						62

Penalty Illustrations

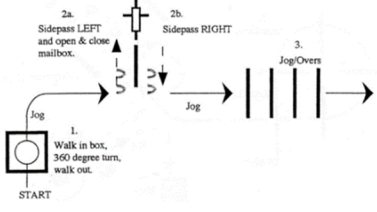
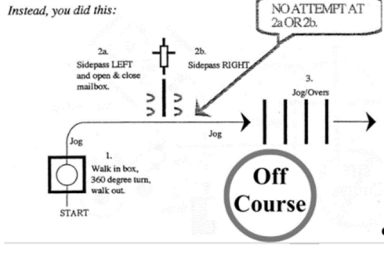
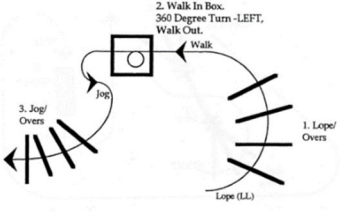
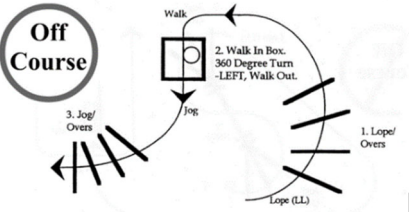
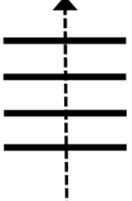
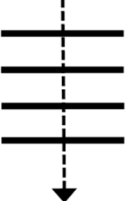
<i>Penalty</i>	<i>Explanation/Illustration</i>
NO SCORE	
Prohibited equipment.	USEF Western Equipment Booklet https://www.usef.org/forms-pubs/5RH4DNG2aJ4/western-equipment This includes any attachment which alters the movement of or circulation to the tail.
Abuse to the animal inside or outside the competition arena and/or evidence that an act of abuse has occurred.	This includes lameness and/or fresh blood in the mouth, chin, shoulder, barrel, flank or hip areas.
Disrespect or misconduct by exhibitor.	
Use of whip in In-Hand Trail.	
0 – Score (Disqualified)	
Use of two hands (except snaffle bit or hackamore classes designated for two hands) or changing hands on reins; except for junior horses shown with hackamore or snaffle bit, only one hand may be used on the reins, except that it is permissible to change hands to work an obstacle as outlined in AR211.1de, or to straighten reins when stopped (Exception: Does not apply for English Trail or In-Hand Trail.)	

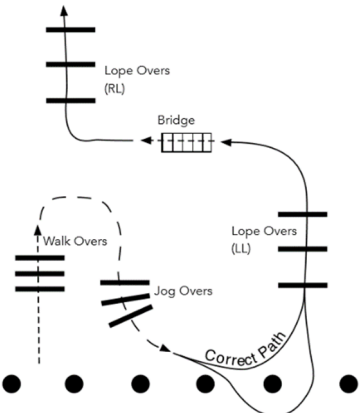
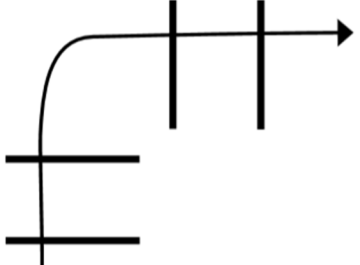
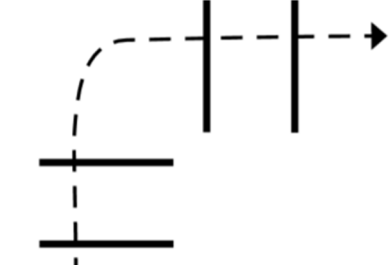
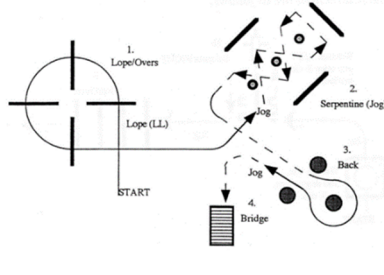
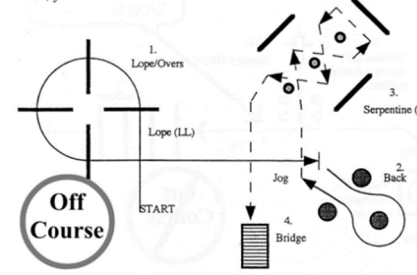
Penalty	Explanation/Illustration
<p>Failure to maintain 16" of rein between hands. (Exception: Does not apply to English Trail or In-Hand Trail.)</p>	<p>16" of rein refers to the length of reins between hands, not the distance between hands.</p>
<p>No attempt to perform an obstacle.</p>	<p>The course directions are as follows:</p>  <p>Instead, you did this:</p> 
<p>Equipment failure that delays completion of pattern excessively or repeatedly touching the horse on the neck to lower the head.</p>	
<p>Entering or exiting an obstacle from the incorrect side or direction.</p>	<p>The course directions are as follows:</p>  <p>Instead, you did this:</p> 
<p>Working obstacle the incorrect direction; including overturns of more than ¼ turn.</p>	 <p>Correct: Negotiate walk overs as drawn.</p>  <p>Incorrect: Negotiate walk overs from wrong side. PENALTY ZERO SCORE</p>

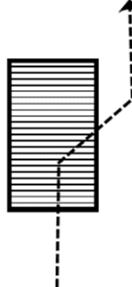
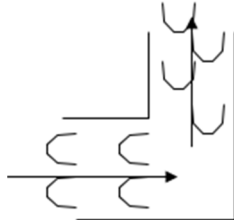
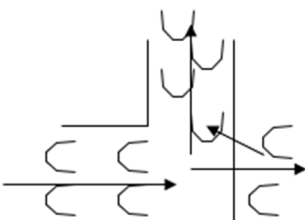
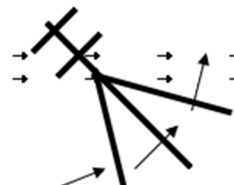
Penalty	Explanation/Illustration
<p>Riding outside designated boundary maker of the arena or course area.</p>	
<p>Failure to ever demonstrate correct gait as designated.</p>	<div style="display: flex; justify-content: space-around;"> <div data-bbox="479 661 836 997">  <p>Correct: Lope Overs (RL)</p> </div> <div data-bbox="950 661 1339 997">  <p>Incorrect: Jog entire obstacle PENALTY ZERO SCORE</p> </div> </div>
<p>Failure to follow the correct line of travel between obstacles excessive schooling, pulling, turning, stepping or backing anywhere on course.</p>	<div style="display: flex; justify-content: space-around;"> <div data-bbox="479 1165 885 1459"> <p><i>The course directions are as follows:</i></p>  </div> <div data-bbox="917 1165 1356 1459"> <p><i>Instead, you did this:</i></p>  </div> </div>
<p>Baiting in In-Hand Trail.</p>	
<p>10-POINT PENALTY</p>	<p><i>A Ten Point Penalty must be assessed for an unnatural tail carriage, see AR105.2b. Effective 12/1/2023</i></p>
<p>5-POINT PENALTIES</p>	
<p>Dropping slicker or object required to be carried on course, each refusal (three</p>	

Penalty	Explanation/Illustration
refusals move to the next obstacle), balk, or evading an obstacle by shying or backing.	
Letting go of gate or dropping rope gate.	
Use of either hand to instill fear or praise.	
Falling or jumping off or out of a bridge or water box with more than one foot once the horse has got onto or into the obstacle.	
Stepping outside of the confines of an obstacle with designated boundaries (i.e. back through, 360 degree box, side pass) with more than one foot once the horse has entered the obstacle.	<div style="display: flex; justify-content: space-around; align-items: center;"> <div data-bbox="467 890 699 1150">  <p style="text-align: center;">CORRECT ¶</p> </div> <div data-bbox="786 919 938 989"> <p>EXAMPLE # 1: ¶ Backing an "L" configuration. ¶</p> </div> <div data-bbox="971 890 1273 1150">  <p style="text-align: center;">5-POINT PENALTY ¶</p> </div> </div>
Missing or evading a pole that is a part of a series of an obstacle with more than one foot.	<div style="display: flex; justify-content: space-around; align-items: center;"> <div data-bbox="467 1289 699 1514">  <p style="text-align: center;">CORRECT → → → → →</p> </div> <div data-bbox="786 1331 938 1379"> <p>EXAMPLE # 1: ¶ Walk/Overs ¶</p> </div> <div data-bbox="971 1289 1203 1514">  <p style="text-align: center;">5-POINT PENALTY ¶</p> </div> </div>
Blatant disobedience (including kicking out, bucking, rearing, striking).	
Holding saddle with either hand (EXCEPTION: Jumps, Elevated Lope Overs, or	

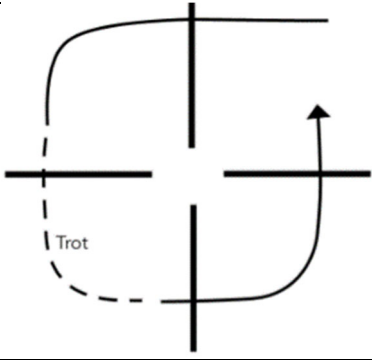
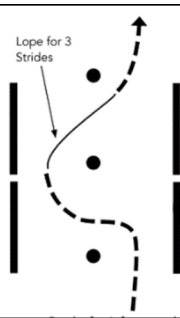
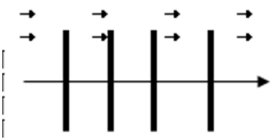
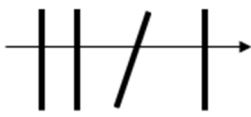
Penalty	Explanation/Illustration
Elevated Jog Overs).	
Handler touching the horse with either hand in In-Hand unless instructed by the judge, course designer or performing a side pass.	
Performing entire obstacle on the wrong lead.	
3-POINT PENALTIES	
Incorrect or break of gait at walk or jog for more than two strides.	 <p>The diagram shows a square obstacle with a vertical pole in the center. A solid line represents the intended path, while a dashed line shows a deviation from the path, labeled 'Trot', indicating a break in gait.</p>
Approaching an obstacle at the wrong gait or lead.	
Out of lead or break of gait at lope (except when correcting an incorrect lead.)	 <p>The diagram shows two vertical poles. A dashed line indicates a path between them, with an arrow pointing to it labeled 'Lope for 3 Strides', illustrating a break in lead or gait.</p>
Knocking down an elevated pole, cone, barrel, plant, obstacle, or severely disturbing an obstacle.	<div style="display: flex; align-items: center;"> <div style="margin-right: 20px;">  <p>→ Horse A completes obstacle with no more than Light-ticks. NO-PENALTY</p> </div> <div style="margin-right: 20px;"> <p>EXAMPLE: [] Lope/Overs []</p> </div> <div>  <p>Horse B noticeably displaces original configuration of poles. [] → 3-POINT-PENALTY []</p> </div> </div>

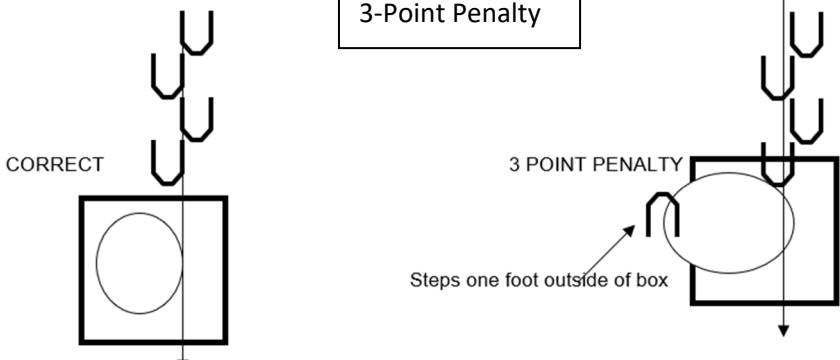
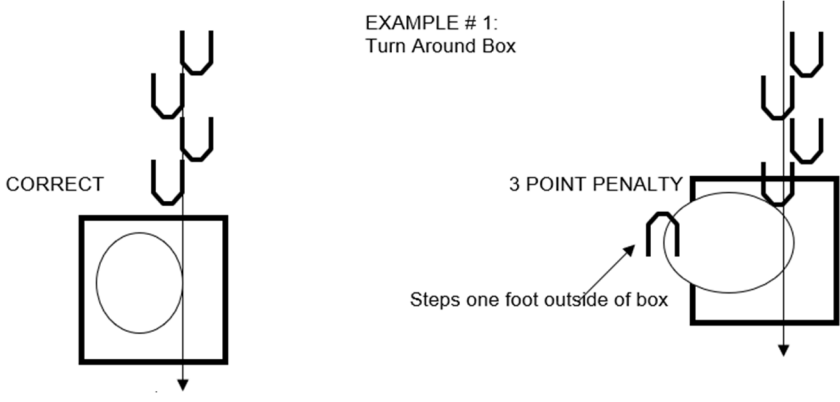
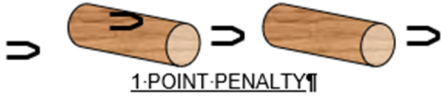
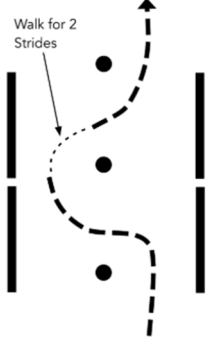
Penalty	Explanation/Illustration
<p>Falling or jumping off or out of a bridge or water box with one foot once the horse has got onto or into that obstacle.</p>	<p style="text-align: center;">3-Point Penalty</p> 
<p>Stepping outside of the confines of an obstacle with designated boundaries (i.e. back through, 360 degree box, side pass) with one foot once the horse has entered the obstacle. Missing or evading a pole that is part of a series of an obstacle with one foot.</p>	<p style="text-align: center;">EXAMPLE # 1: Turn Around Box</p> 
1-POINT PENALTIES	
<p>Each hard hit, bite, or stepping on a log, cone, plant, or a component of the obstacle.</p>	
<p>Incorrect or break of gait at walk or jog for two strides or less; both front or hind feet in a single-strided slot or space at a walk or jog.</p>	

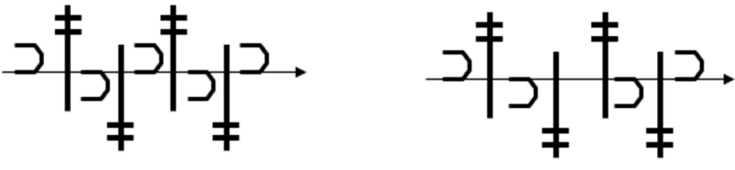
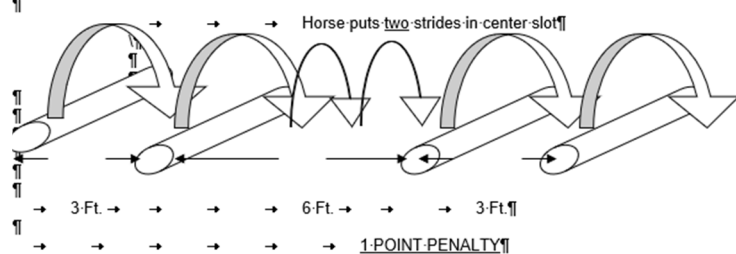
Penalty	Explanation/Illustration
<p>Skipping over or failing to step into required space; split pole in lope-over.</p>	
<p>Incorrect number of strides, if specified.</p>	 <p>Horse puts <u>two</u> strides in center slot!</p> <p>3-Ft. → → → → 6-Ft. → → → 3-Ft.!</p> <p>→ → → → → → → 1-POINT-PENALTY!</p>



Trail Horse Score Sheet

SHOW _____ DATE: _____

CLASS NO: _____ Class Title: _____

Scores +3 = Excellent; +2 = Very Good; +1 = Good; 0 = Average; -1 = Poor; -2 = Very Poor; -3 = Extremely Poor

		<div style="display: flex; justify-content: space-around;"> ///////////// </div>														
DRAW	ENTRY		1	2	3	4	5	6	7	8	9	10	11	12	Penalties	
		Penalties														
		Score														
		Subtotal														
		Penalties														
		Score														
		Subtotal														
		Penalties														
		Score														
		Subtotal														
		Penalties														
		Score														
		Subtotal														
		Penalties														
		Score														
		Subtotal														
		Penalties														
		Score														
		Subtotal														

TRAIL HORSE SCORE SHEET.DOC EEC 061504

JUDGE SIGNATURE _____ Page # _____ of _____

SAMPLE TRAIL COURSE BASIC LEVEL

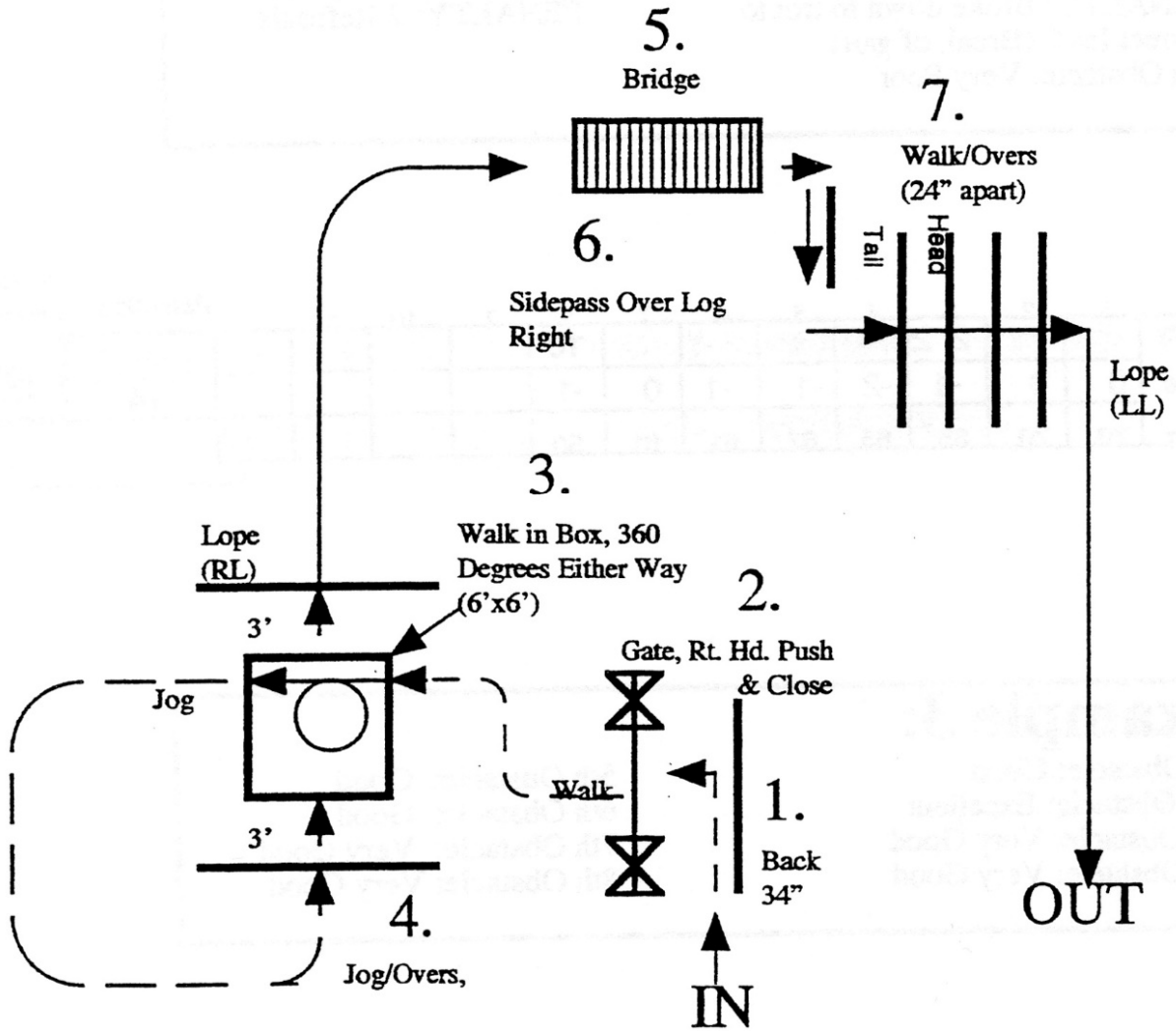

***NOTE:** Dimensions may require adjustment depending on arena conditions, size of equipment, caliber of competition, etc. Use these dimensions as guidelines.

SAMPLE TRAIL COURSE INTERMEDIATE LEVEL

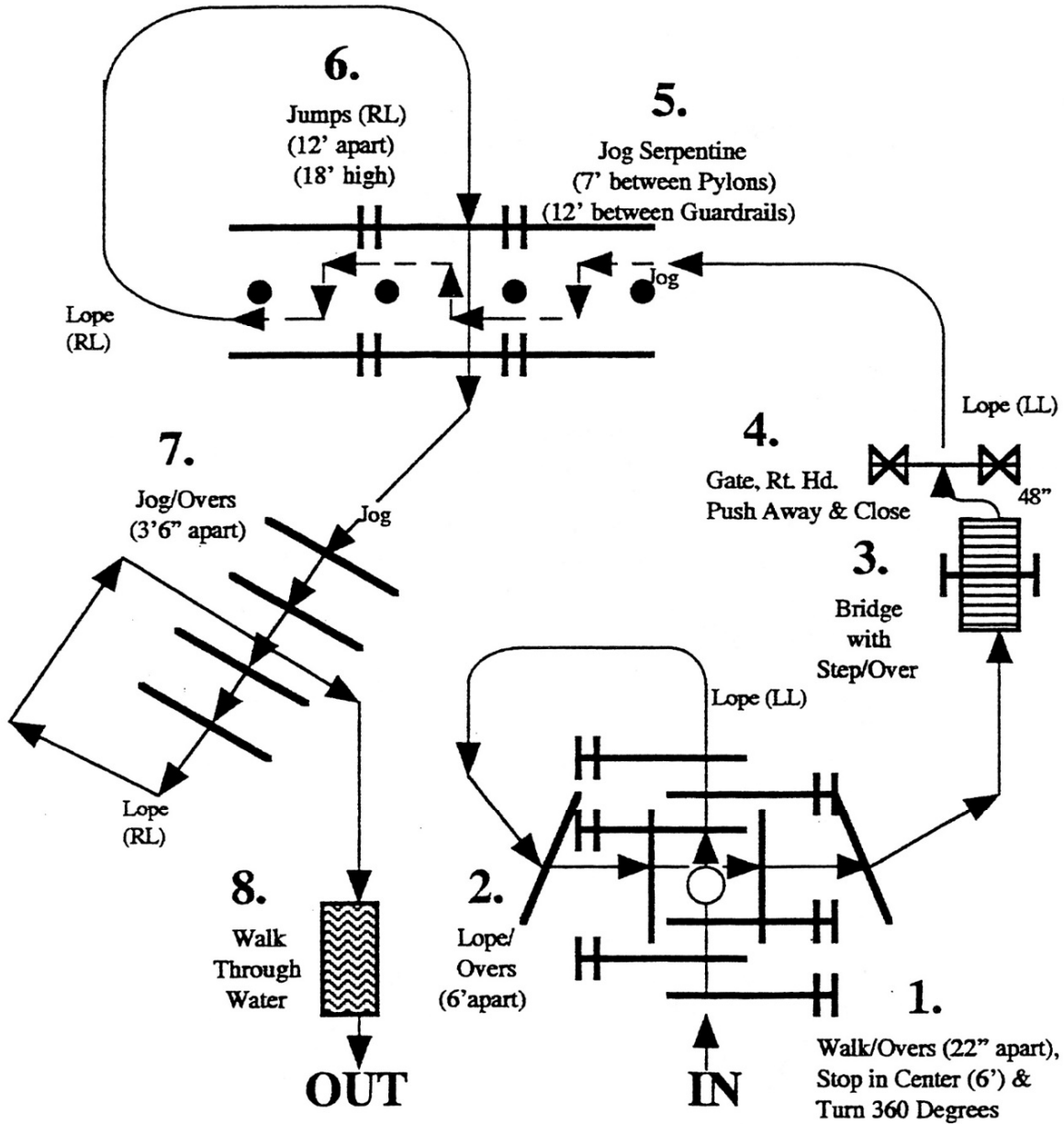

***NOTE:** Dimensions may require adjustment depending on arena conditions, size of equipment, caliber of competition, etc. Use these dimensions as guidelines.

SAMPLE TRAIL COURSE ADVANCED LEVEL

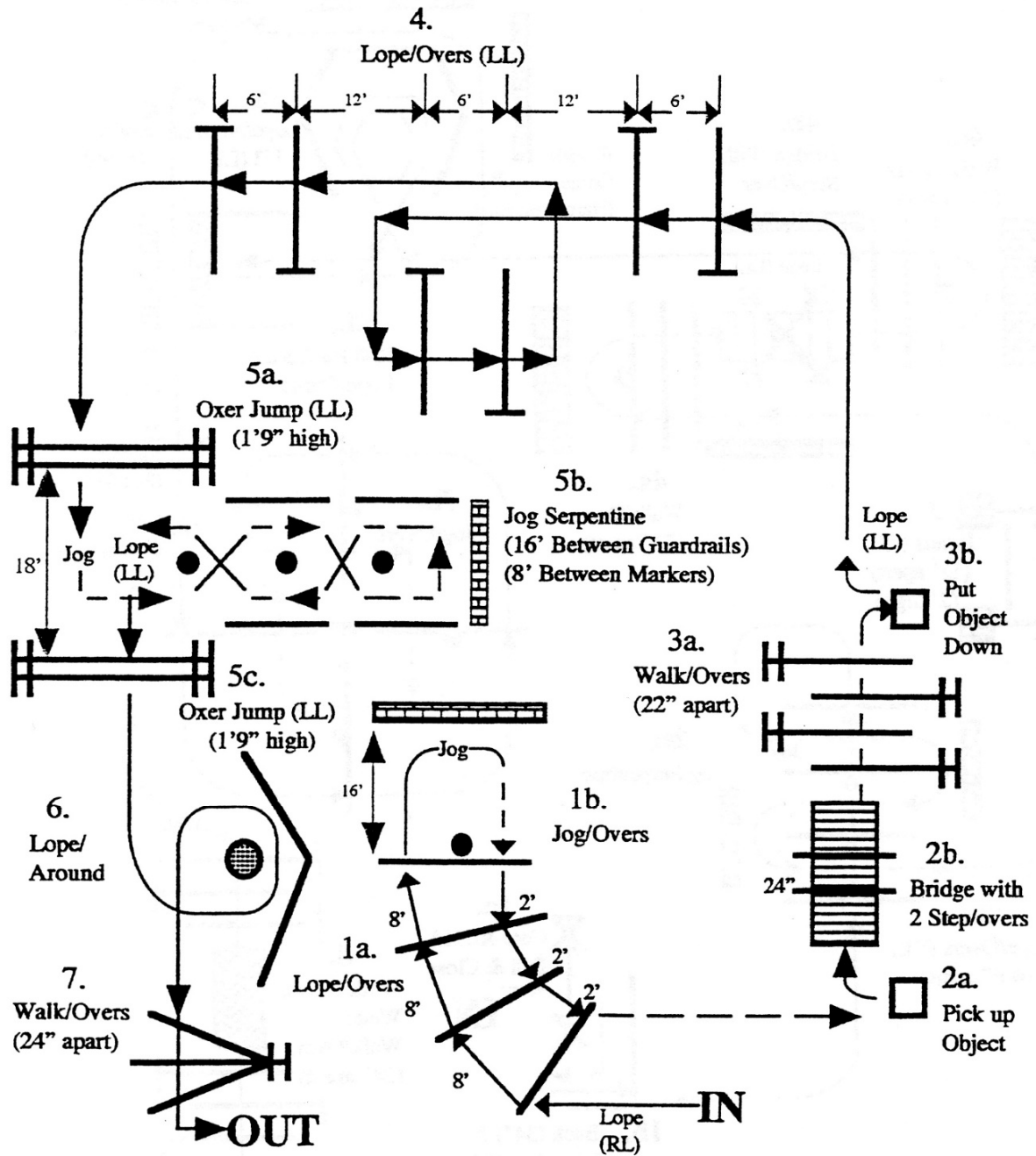

***NOTE:** Dimensions may require adjustment depending on arena conditions, size of equipment, caliber of competition, etc. Use these dimensions as guidelines.

Prepared by the

Education & Evaluation Commission and the
Judges & Stewards Commissioner
6030 Greenwood Plaza Blvd, Suite 100
Greenwood Village, CO 80111
303-696-4539