

# 2024 US Nationals

## 1198 Arabian & 1199 HA/AA Reined Cow AATR SF/F



# PATTERN 4

May be used for NHSRA Events

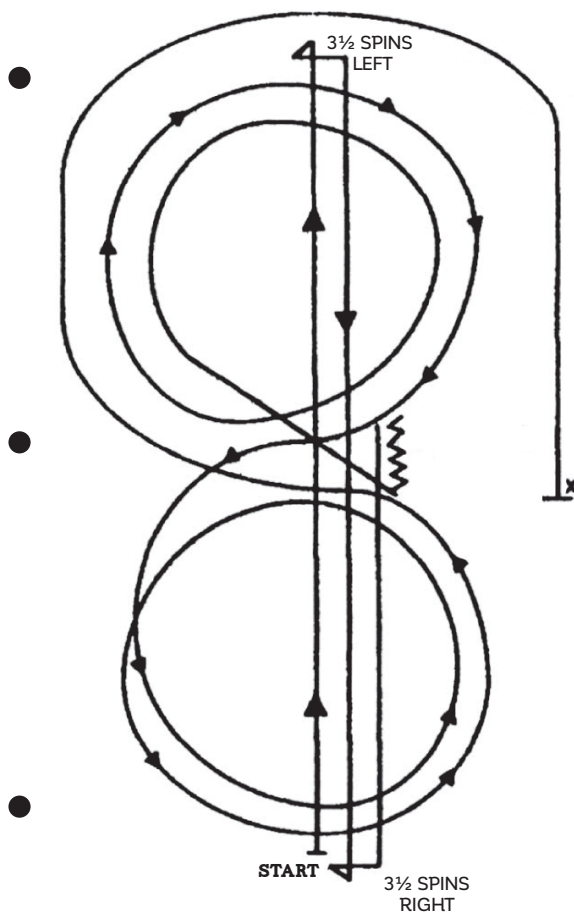

1. Start at end of arena. Run up center of arena past the end marker and come to a sliding stop.
2. Complete 3½ spins to the left.
3. Run to other end of arena past the end marker and stop.
4. Complete 3½ spins to the right.
5. Run past the center marker and stop. Back at least 10 feet in a straight line. Complete a 1/4 turn to the left.
6. Beginning on the right lead, complete two circles to the right, the first one small and slow, and the second large and fast. Change leads at the center of the arena.
7. Complete one small and slow circle and one large and fast circle, Change leads to the right.
8. Run around end of arena to the other side, past center marker, at least 20 feet from fence and come to sliding stop. Hesitate to complete pattern.

# 2024 US Nationals

260 Arabian Reined Open & 1135 Limited Reined AATR

705 HA/AA Reined Cow Open & 1199 Limited Reined AATR

SF/F



## PATTERN 2 LOPE TOWARD

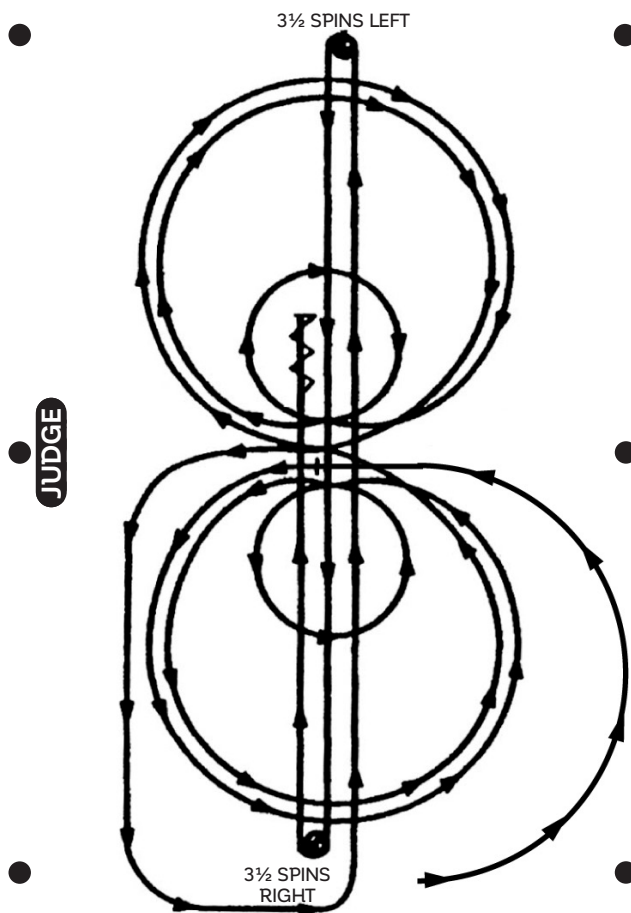

Begin on left lead. At the center, without stopping or breaking gait, begin pattern facing toward the judge. Refer to rule 20.6

1. Beginning on the left lead, complete 3 circles to the left. The first one large and fast, the second small and slow, the third large and fast. Change leads at the center of arena.
2. Complete 3 circles to the right. The first one large and fast, the second small and slow, and the third large and fast. Change leads at the center of arena.
3. Continue loping to run down. Run to far end past the marker to a sliding stop.
4. Complete 3 ½ spins to the left.
5. Run to far end past marker to a sliding stop.
6. Complete 3 ½ spins to the right.
7. Run past center marker to a sliding stop. Back at least 10 feet. Hesitate to complete pattern.